

L:  
 CBL-HFD3SAB6CS-6m 6000mm±30mm  
 CBL-HFD3SAB6CS-7m 7000mm±30mm  
 CBL-HFD3SAB6CS-8m 8000mm±30mm  
 CBL-HFD3SAB6CS-9m 9000mm±30mm  
 CBL-HFD3SAB6CS-10m 10000mm±30mm

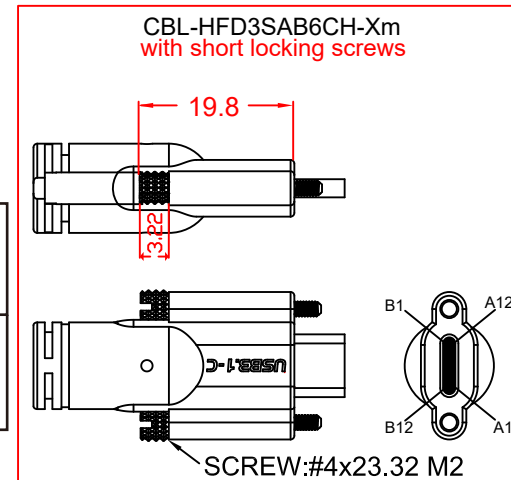

No	MATERIALS LIST:
1.	CABLE: 3 x (2 x 24 AWG)ST + 2 x 22 AWG O.D.:8.8mm COLOR:RED LILAC
2.	CONNECTOR:USB 3.0 A/M, 9P, BLUE INSULATOR SOLDER TYPE, NICKEL PLATED SHELL
3.	CONNECTOR:USB 3.1 TYPE-C, MALE, NICKEL PLATED SHELL
4.	PVC MOLDED HOUSING, BLACK COLOR
5.	SCREW:#4x33 M2

Jargy part no.	Client part no.	Approved	SCALE	UNIT
CBL-HFD3SAB6CS-xm				mm
Drawing Name		Drawn	Date	REV.
USB 3.1 GEN 1 A to C Cable M/M				1.0

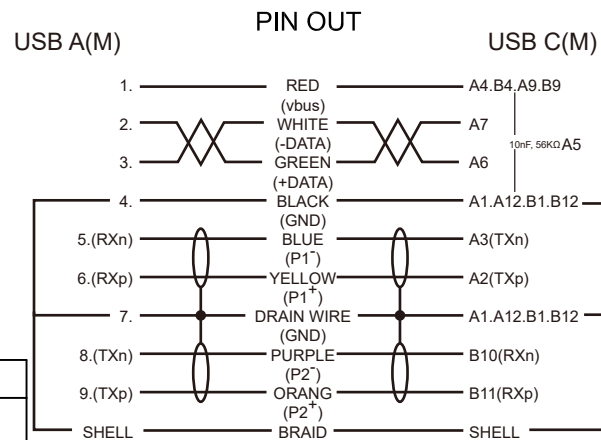
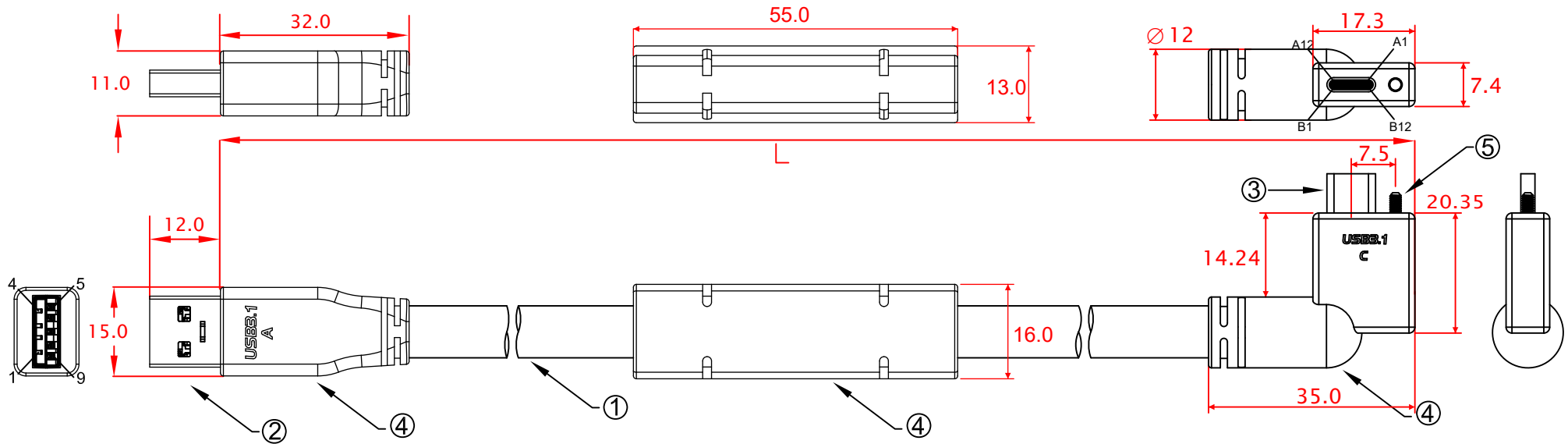

- L:
- CBL-HFD3SAB6CH-6mLRA 6000mm±30mm
  - CBL-HFD3SAB6CH-7mLRA 7000mm±30mm
  - CBL-HFD3SAB6CH-8mLRA 8000mm±30mm
  - CBL-HFD3SAB6CH-9mLRA 9000mm±30mm
  - CBL-HFD3SAB6CH-10mLRA 10000mm±30mm

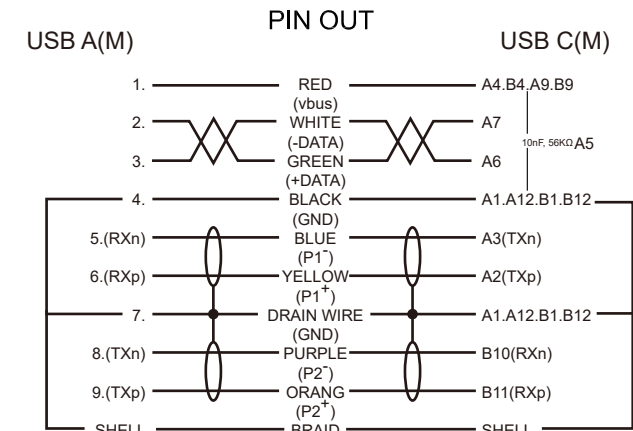

No	MATERIALS LIST:
1.	CABLE: 3 x (2 x 24 AWG)ST + 2 x 22 AWG O.D.:8.8mm COLOR:RED LILAC
2.	CONNECTOR:USB 3.0 A/M, 9P, BLUE INSULATOR SOLDER TYPE, NICKEL PLATED SHELL
3.	CONNECTOR:USB 3.1 TYPE-C, MALE, NICKEL PLATED SHELL
4.	PVC MOLDED HOUSING, BLACK COLOR
5.	SCREW:#4x23.32 M2

Jargy part no.	Client part no.	Approved	SCALE	UNIT
CBL-HFD3SAB6CH-xmLRA				mm
Drawing Name		Drawn	Date	REV.
USB 3.1 GEN 1 A to C Cable M/M				1.0

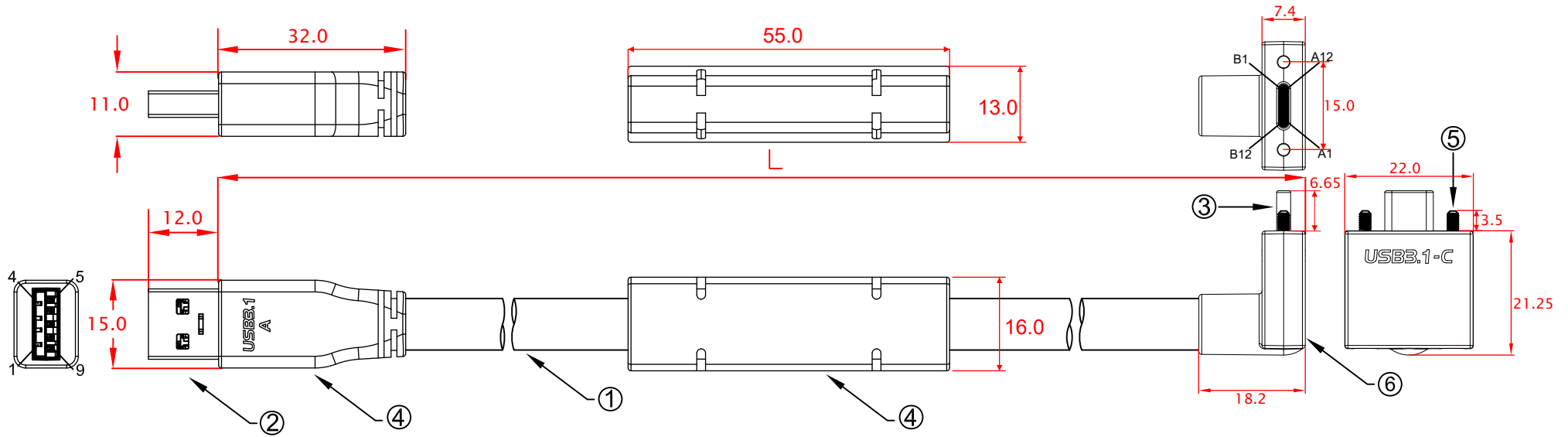

L:

CBL-HFD3SAB6CH-6mUDA	6000mm±30mm
CBL-HFD3SAB6CH-7mUDA	7000mm±30mm
CBL-HFD3SAB6CH-8mUDA	8000mm±30mm
CBL-HFD3SAB6CH-9mUDA	9000mm±30mm
CBL-HFD3SAB6CH-10mUDA	10000mm±30mm

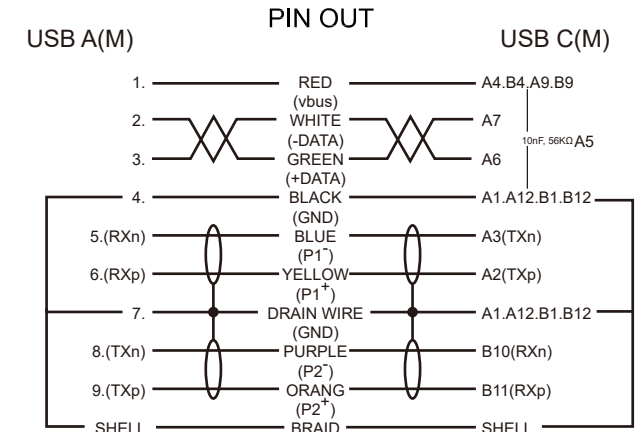

No	MATERIALS LIST:
1.	CABLE: 3 x (2 x 24 AWG)ST + 2 x 22 AWG O.D.:8.8mm COLOR:RED LILAC
2.	CONNECTOR:USB 3.0 A/M, 9P, BLUE INSULATOR SOLDER TYPE, NICKEL PLATED SHELL
3.	CONNECTOR:USB 3.1 TYPE-C, MALE, NICKEL PLATED SHELL
4.	PVC MOLDED HOUSING, BLACK COLOR
5.	SCREW:#4x23.32 M2
6.	ABS ASSEMBLY HOUSING, BLACK COLOR

Jargy part no.	Client part no.	Approved	SCALE	UNIT
CBL-HFD3SAB6CH-xmUDA				mm
Drawing Name		Drawn	Date	REV.
USB 3.1 GEN 1 A to C Cable M/M				1.0

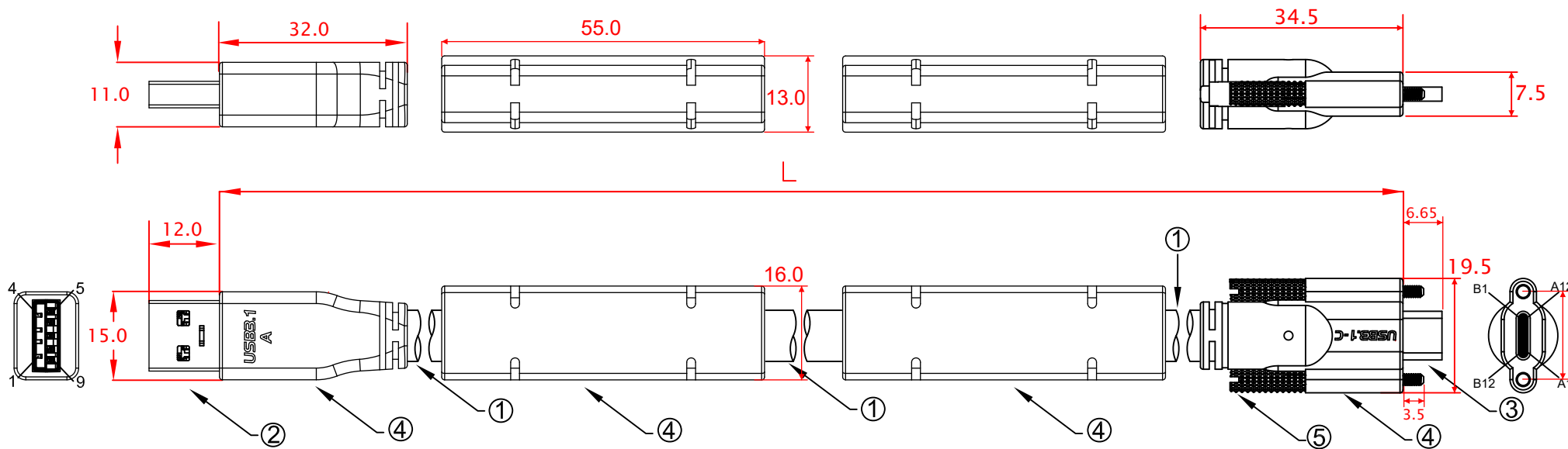

L:

CBL-HFD3SAB6CS-11m	11000±50mm
CBL-HFD3SAB6CS-12m	12000±50mm
CBL-HFD3SAB6CS-13m	13000±50mm
CBL-HFD3SAB6CS-14m	14000±50mm

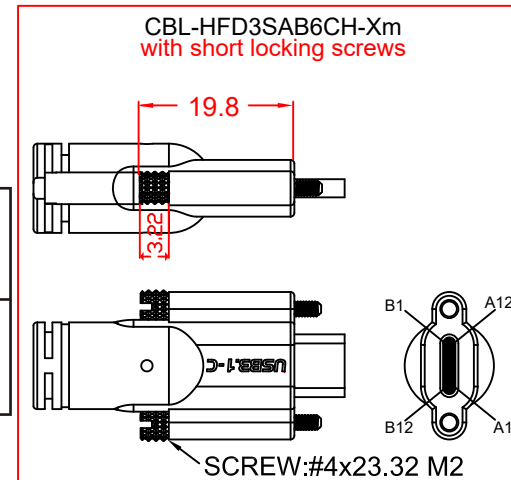
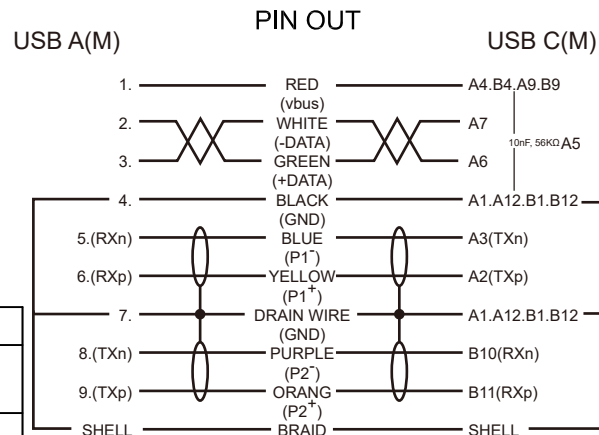

No	MATERIALS LIST:
1.	CABLE: 3 x (2 x 24 AWG)ST + 2 x 22 AWG O.D.:8.8mm COLOR:RED LILAC
2.	CONNECTOR:USB 3.0 A/M, 9P, BLUE INSULATOR SOLDER TYPE, NICKEL PLATED SHELL
3.	CONNECTOR:USB 3.1 TYPE-C, MALE, NICKEL PLATED SHELL
4.	PVC MOLDED HOUSING, BLACK COLOR
5.	SCREW:#4x33 M2
6.	

Jargy part no.	Client part no.	Approved	SCALE	UNIT
CBL-HFD3SAB6CS-xm				mm
Drawing Name		Drawn	Date	REV.
USB 3.1 GEN 1 A to C Cable M/M				1.0



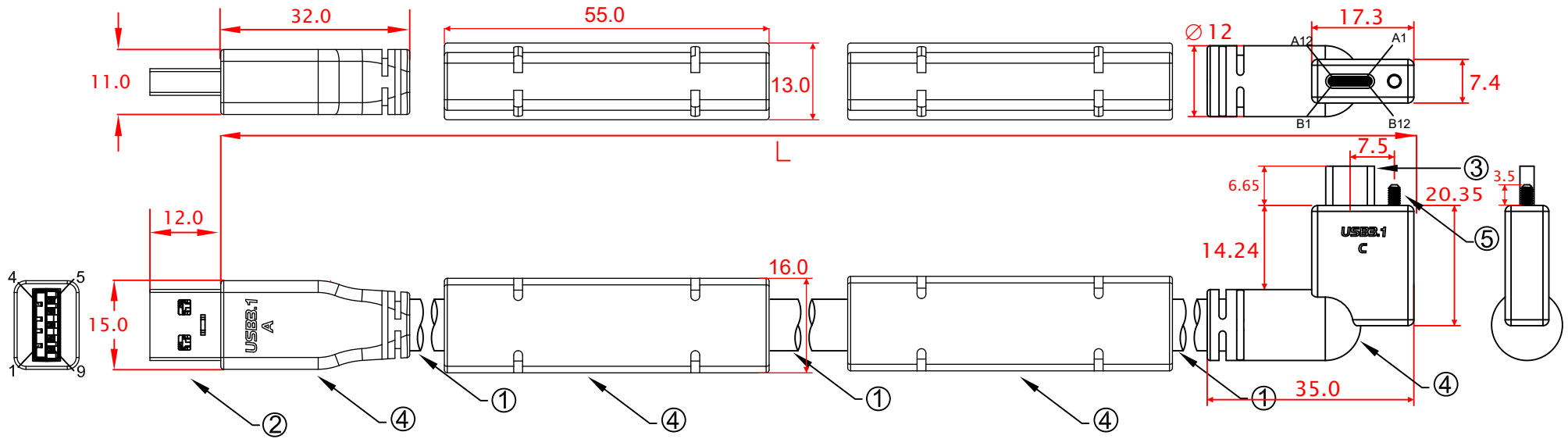

L:

CBL-HFD3SAB6CH-11mLRA	11000±50mm
CBL-HFD3SAB6CH-12mLRA	12000±50mm
CBL-HFD3SAB6CH-13mLRA	13000±50mm
CBL-HFD3SAB6CH-14mLRA	14000±50mm

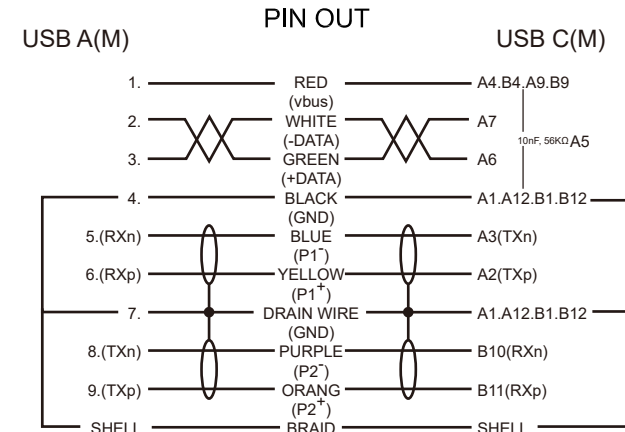

No	MATERIALS LIST:
1.	CABLE: 3 x (2 x 24 AWG)ST + 2 x 22 AWG O.D.:8.8mm COLOR:RED LILAC
2.	CONNECTOR:USB 3.0 A/M, 9P, BLUE INSULATOR SOLDER TYPE, NICKEL PLATED SHELL
3.	CONNECTOR:USB 3.1 TYPE-C, MALE, NICKEL PLATED SHELL
4.	PVC MOLDED HOUSING, BLACK COLOR
5.	SCREW:#4x23.32 M2
6.	

Jargy part no.	Client part no.	Approved	SCALE	UNIT
CBL-HFD3SAB6CH-xmLRA				mm
Drawing Name		Drawn	Date	REV.
USB 3.1 GEN 1 A to C Cable M/M				1.0

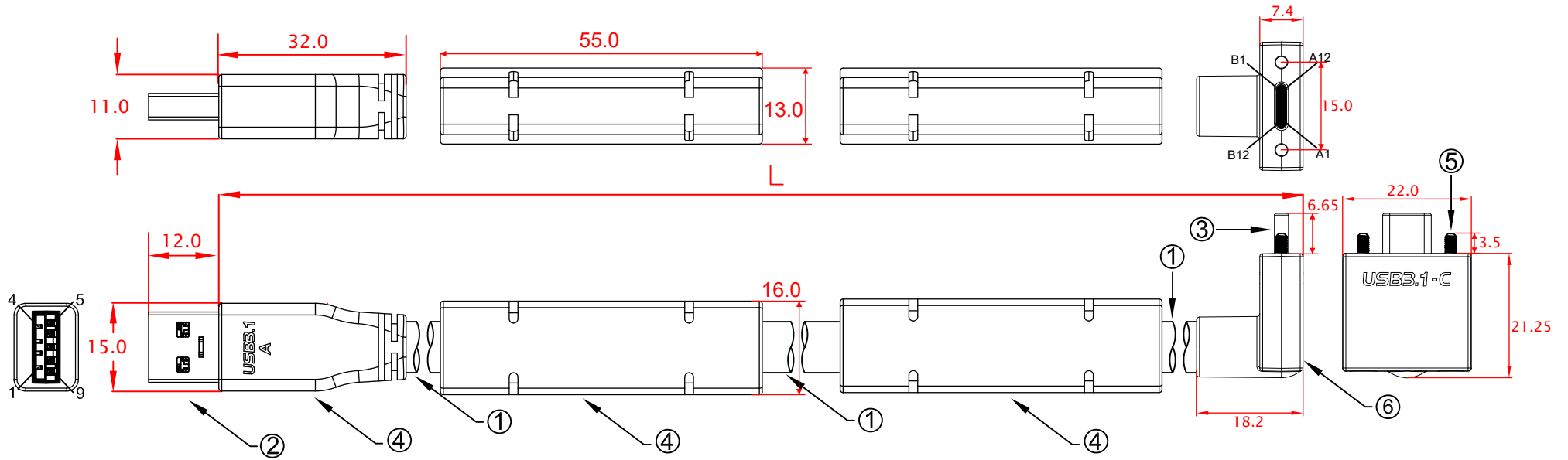

- L:  
 CBL-HFD3SAB6CH-11mUDA 11000±50mm  
 CBL-HFD3SAB6CH-12mUDA 12000±50mm  
 CBL-HFD3SAB6CH-13mUDA 13000±50mm  
 CBL-HFD3SAB6CH-14mUDA 14000±50mm

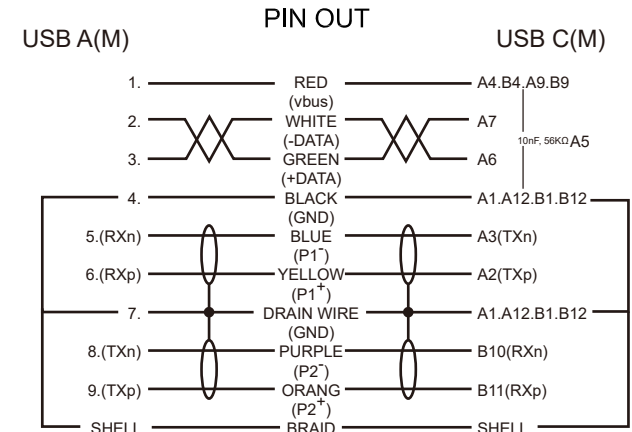

No	MATERIALS LIST:
1.	CABLE: 3 x (2 x 24 AWG)ST + 2 x 22 AWG O.D.:8.8mm COLOR:RED LILAC
2.	CONNECTOR:USB 3.0 A/M, 9P, BLUE INSULATOR SOLDER TYPE, NICKEL PLATED SHELL
3.	CONNECTOR:USB 3.1 TYPE-C, MALE, NICKEL PLATED SHELL
4.	PVC MOLDED HOUSING, BLACK COLOR
5.	SCREW:#4x23.32 M2
6.	ABS ASSEMBLY HOUSING, BLACK COLOR

Jargy part no.	Client part no.	Approved	SCALE	UNIT
CBL-HFD3SAB6CH-xmUDA				mm
Drawing Name		Drawn	Date	REV.
USB 3.1 GEN 1 A to C Cable M/M				1.0

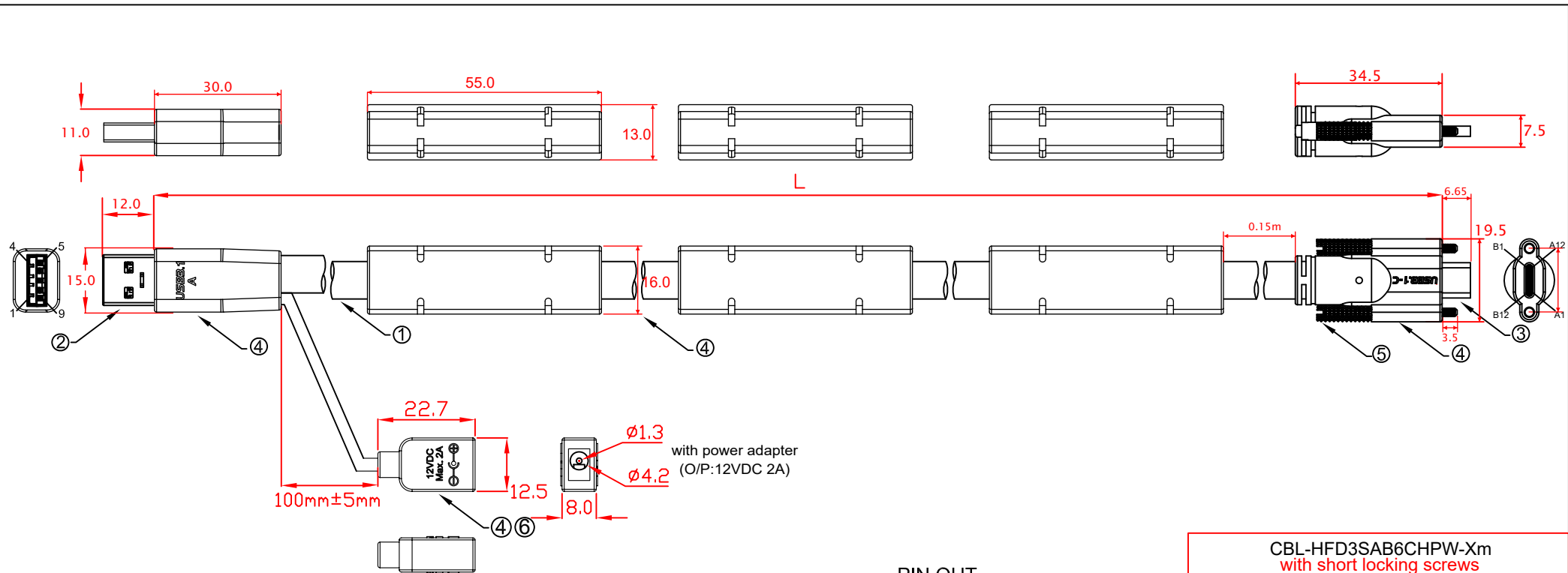

L:  
CBL-HFD3SAB6CSPW-15m 15000mm±50mm

No	MATERIALS LIST:
1.	CABLE: 3 x (2 x 24 AWG)ST + 2 x 22 AWG O.D.:8.8mm COLOR:RED LILAC
2.	CONNECTOR:USB 3.0 A/M, 9P, BLUE INSULATOR SOLDER TYPE, NICKEL PLATED SHELL
3.	CONNECTOR:USB 3.1 TYPE-C, MALE, NICKEL PLATED SHELL
4.	PVC MOLDED HOUSING, BLACK COLOR
5.	SCREW:#4x33 M2
6.	DC JACK 1.3mm 30V 0.3V

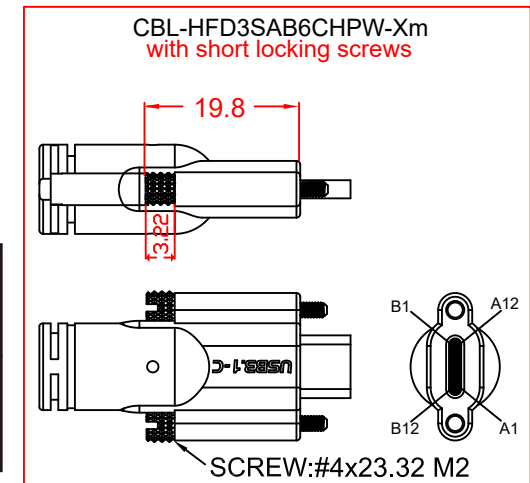
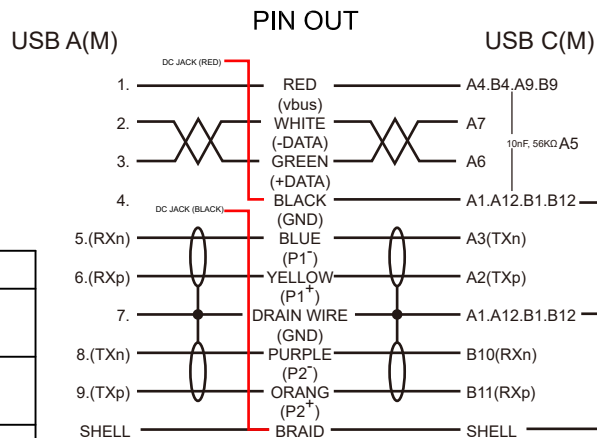

Jargy part no.	Client part no.	Approved	SCALE	UNIT
CBL-HFD3SAB6CSPW-xm				mm
Drawing Name		Drawn	Date	REV.
USB 3.1 GEN 1 A to C Cable M/M				1.0

**Mobile Computing JARGY**

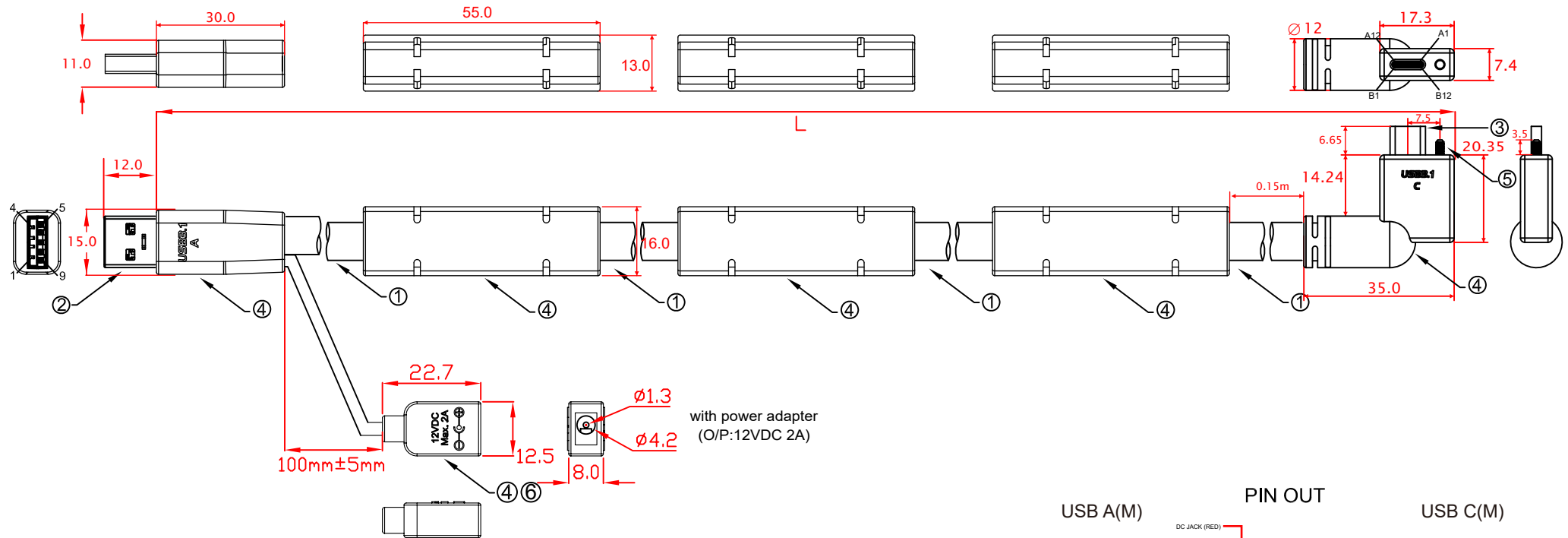

L:  
CBL-HFD3SAB6CHPW-15mLRA 15000mm±50mm

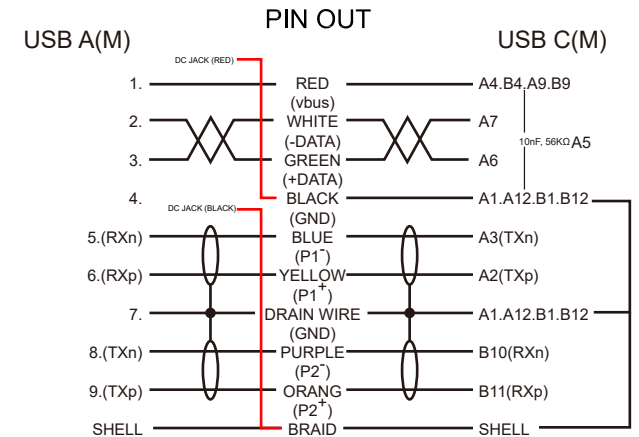

No	MATERIALS LIST:
1.	CABLE: 3 x (2 x 24 AWG)ST + 2 x 22 AWG O.D.:8.8mm COLOR:RED LILAC
2.	CONNECTOR:USB 3.0 A/M, 9P, BLUE INSULATOR SOLDER TYPE, NICKEL PLATED SHELL
3.	CONNECTOR:USB 3.1 TYPE-C, MALE, NICKEL PLATED SHELL
4.	PVC MOLDED HOUSING, BLACK COLOR
5.	SCREW:#4x23.32 M2
6.	DC JACK 1.3mm 30V 0.3V

Jargy part no.	Client part no.	Approved	SCALE	UNIT
CBL-HFD3SAB6CHPW-xmLRA				mm
Drawing Name		Drawn	Date	REV.
USB 3.1 GEN 1 A to C Cable M/M				1.0



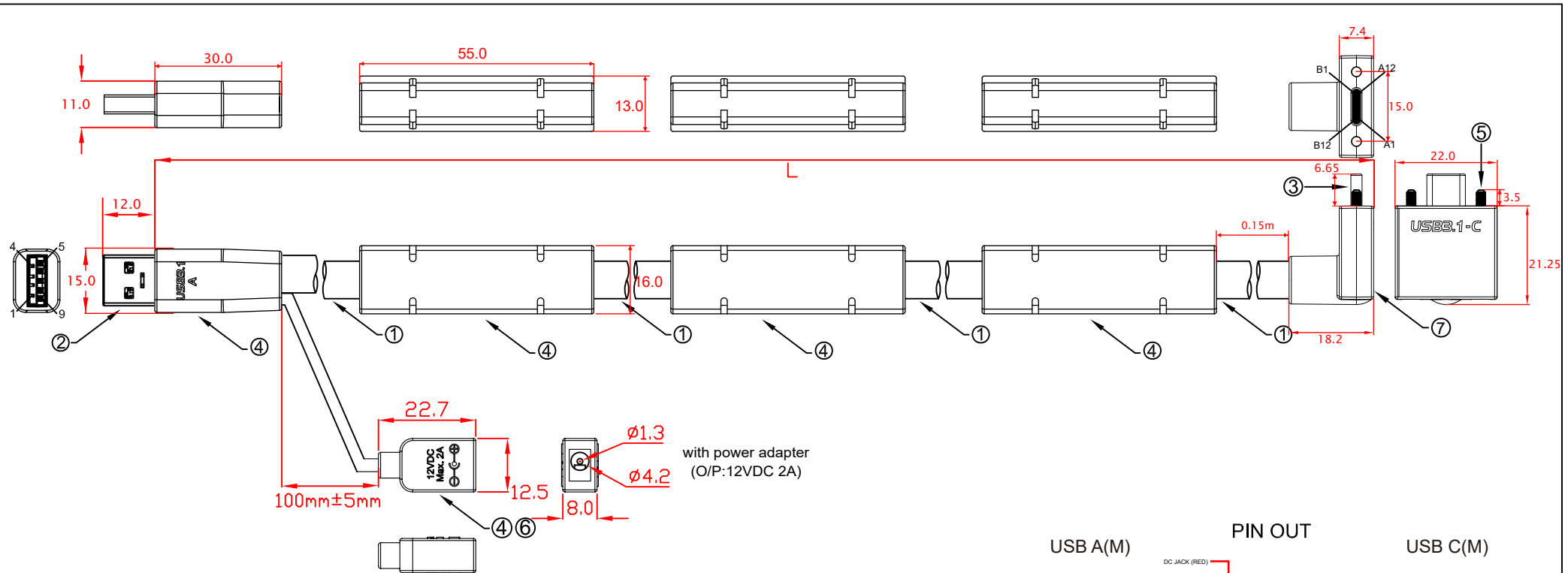

L:  
CBL-HFD3SAB6CHPW-15mUDA 15000mm±50mm

No	MATERIALS LIST:
1.	CABLE: 3 x (2 x 24 AWG)ST + 2 x 22 AWG O.D.:8.8mm COLOR:RED LILAC
2.	CONNECTOR:USB 3.0 A/M, 9P, BLUE INSULATOR SOLDER TYPE, NICKEL PLATED SHELL
3.	CONNECTOR:USB 3.1 TYPE-C, MALE, NICKEL PLATED SHELL
4.	PVC MOLDED HOUSING, BLACK COLOR
5.	SCREW:#4x23.32 M2
6.	DC JACK 1.3mm 30V 0.3V
7.	ABS ASSEMBLY HOUSING, BLACK COLOR

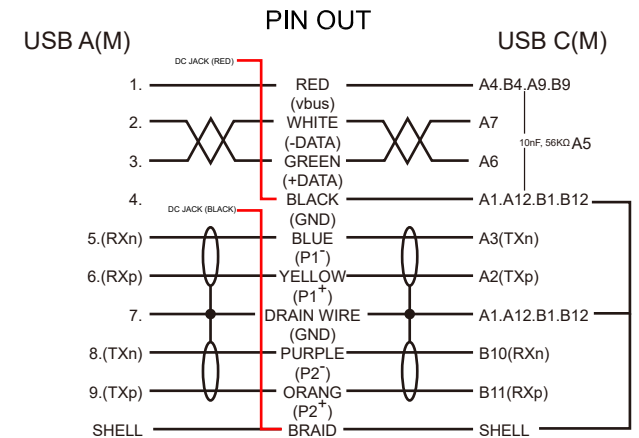

Jargy part no.	Client part no.	Approved	SCALE	UNIT
CBL-HFD3SAB6CHPW-xmUDA				mm
Drawing Name		Drawn	Date	REV.
USB 3.1 GEN 1 A to C Cable M/M				1,0

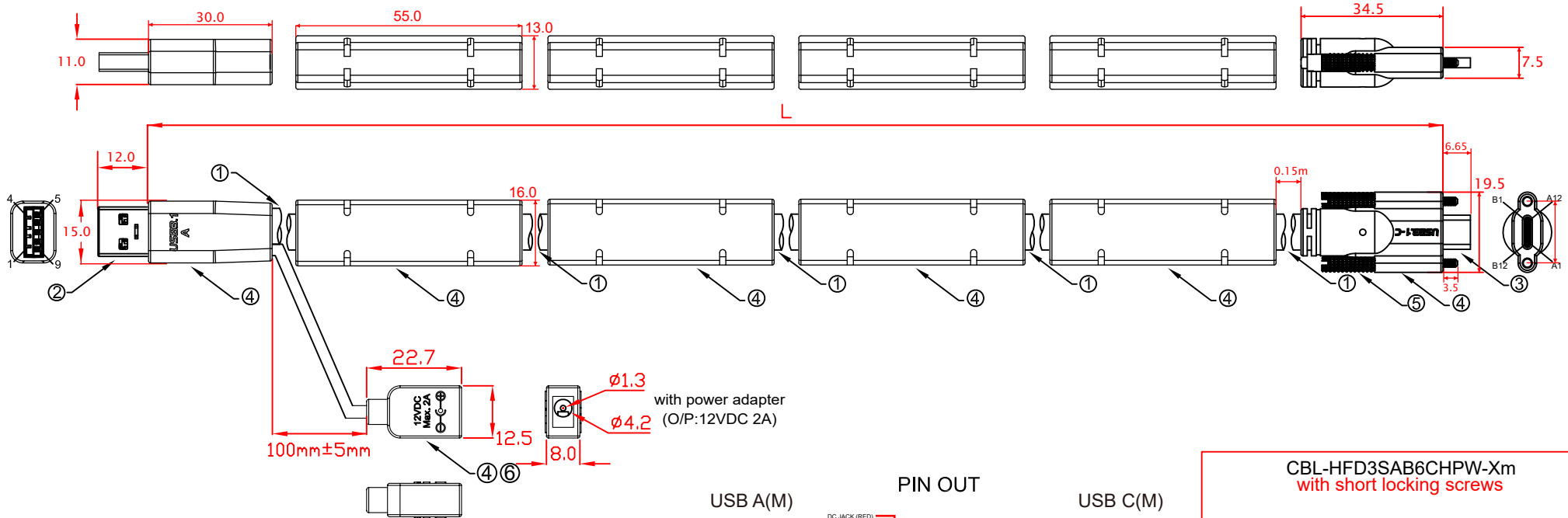

L:  
CBL-HFD3SAB6CSPW-20m      20000±50mm

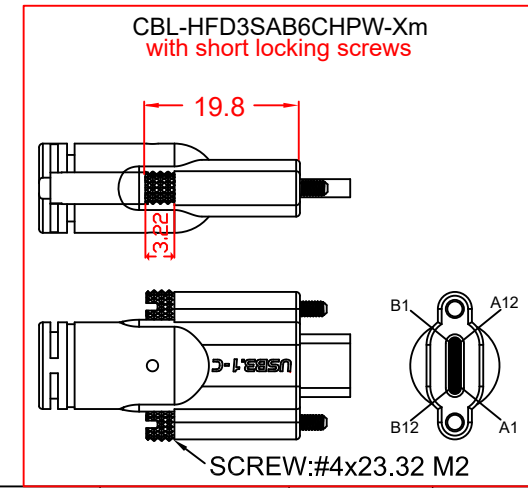
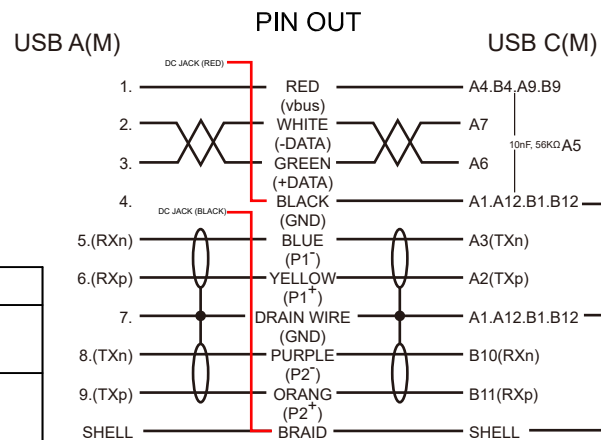

No	MATERIALS LIST:
1.	CABLE: 3 x (2 x 24 AWG)ST + 2 x 22 AWG O.D.:8.8mm COLOR:RED LILAC
2.	CONNECTOR:USB 3.0 A/M, 9P, BLUE INSULATOR SOLDER TYPE, NICKEL PLATED SHELL
3.	CONNECTOR:USB 3.1 TYPE-C, MALE, NICKEL PLATED SHELL
4.	PVC MOLDED HOUSING, BLACK COLOR
5.	SCREW:#4x33 M2
6.	DC JACK 1.3mm 30V 0.3V

Jargy part no.	Client part no.	Approved	SCALE	UNIT
CBL-HFD3SAB6CSPW-xm				mm
Drawing Name		Drawn	Date	REV.
USB 3.1 GEN 1 A to C Cable M/M				1.0

**Mobile Computing JARGY**

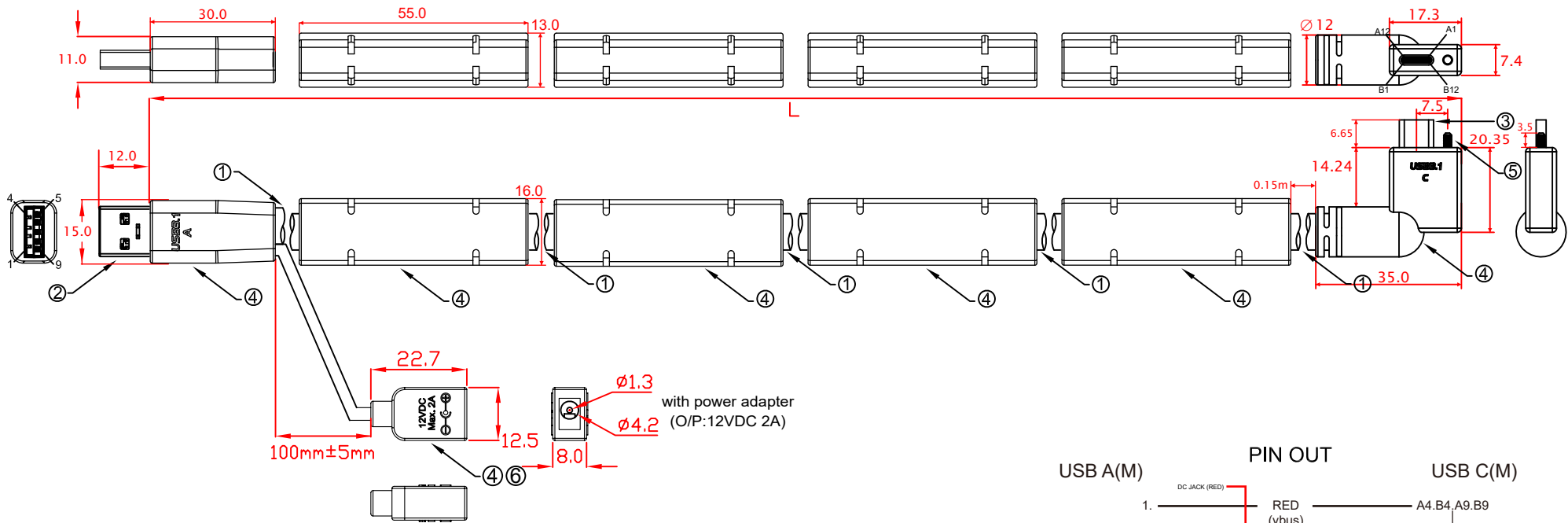

L:  
CBL-HFD3SAB6CHPW-20mLRA 20000±50mm

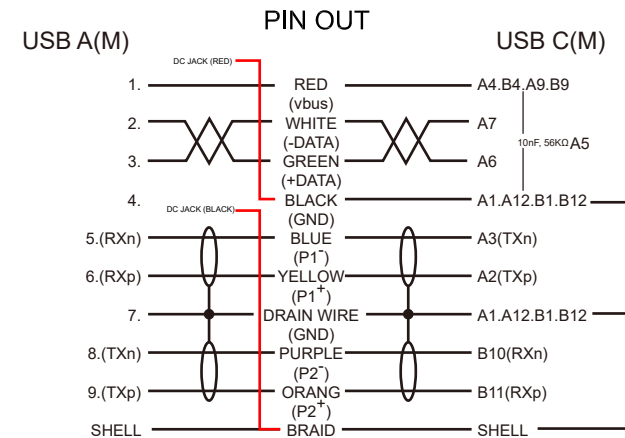

No	MATERIALS LIST:
1.	CABLE: 3 x (2 x 24 AWG)ST + 2 x 22 AWG O.D.:8.8mm COLOR:RED LILAC
2.	CONNECTOR:USB 3.0 A/M, 9P, BLUE INSULATOR SOLDER TYPE, NICKEL PLATED SHELL
3.	CONNECTOR:USB 3.1 TYPE-C, MALE, NICKEL PLATED SHELL
4.	PVC MOLDED HOUSING, BLACK COLOR
5.	SCREW:#4x23.32 M2
6.	DC JACK 1.3mm 30V 0.3V

Jargy part no.	Client part no.	Approved	SCALE	UNIT
CBL-HFD3SAB6CHPW-xmLRA				mm
Drawing Name		Drawn	Date	REV.
USB 3.1 GEN 1 A to C Cable M/M				1.0

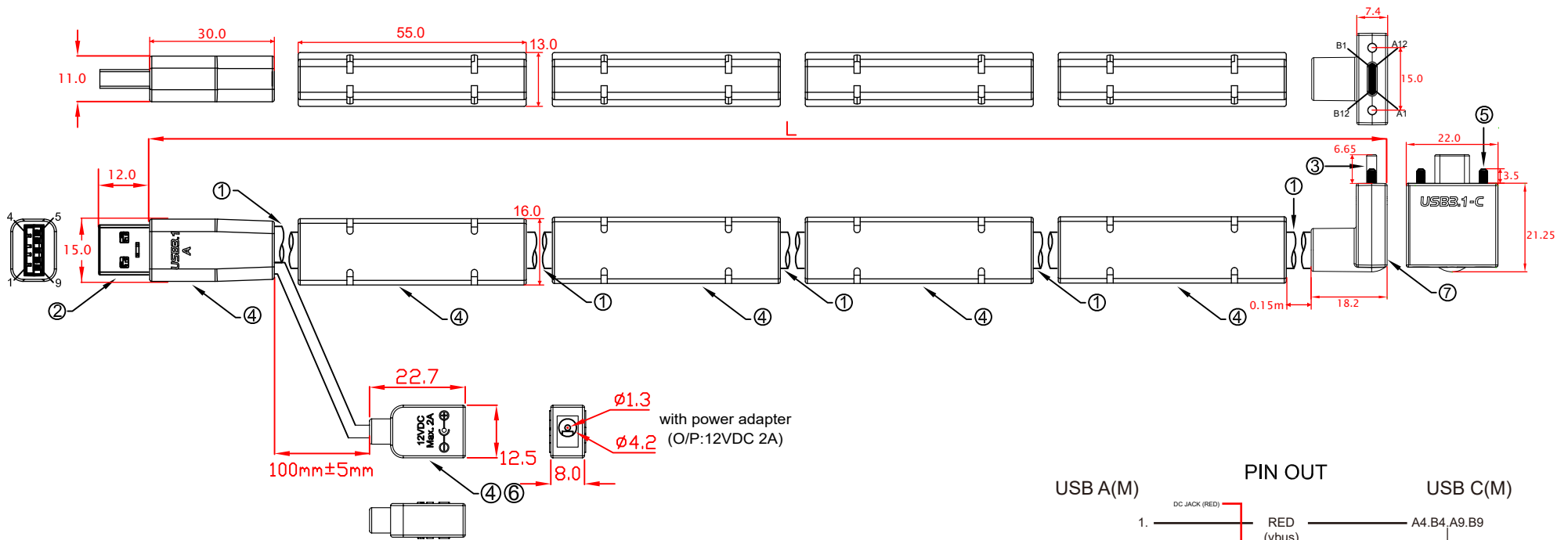

L:  
CBL-HFD3SAB6CHPW-20mUDA 20000±50mm

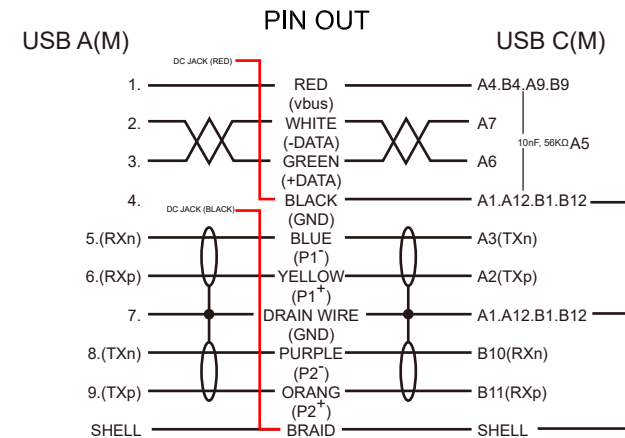

No	MATERIALS LIST:
1.	CABLE: 3 x (2 x 24 AWG)ST + 2 x 22 AWG O.D.:.8mm COLOR:RED LILAC
2.	CONNECTOR:USB 3.0 A/M, 9P, BLUE INSULATOR SOLDER TYPE, NICKEL PLATED SHELL
3.	CONNECTOR:USB 3.1 TYPE-C, MALE, NICKEL PLATED SHELL
4.	PVC MOLDED HOUSING, BLACK COLOR
5.	SCREW:#4x23.32 M2
6.	DC JACK 1.3mm 30V 0.3V
7.	ABS ASSEMBLY HOUSING, BLACK COLOR

Jargy part no.	Client part no.	Approved	SCALE	UNIT
CBL-HFD3SAB6CHPW-xmUDA				mm
Drawing Name		Drawn	Date	REV.
USB 3.1 GEN 1 A to C Cable M/M				1.0